



DBK16™

2-Channel Strain Gage Expansion Card



Compatibility: ✓ LogBook ✓ DaqBook ✓ DaqLab ✓ DaqScan ✓ DaqBoard/2000 Series

Features

- Provides two channels of strain gage inputs
- Accommodates most bridge type sensors, including 4-element full bridges

A 2-channel strain gage expansion card for IOtech's data acquisition systems, the DBK16™ is a general-purpose card that accommodates the connection of most strain gage types, from single-element quarter bridges to 4-element full bridges. The DBK16 also includes provisions for bridge completion resistors and provides four adjustments on each of its two channels. You can adjust excitation voltage, input gain, offset nulling, and output scaling. Up to eight DBK16 boards can be connected to one analog input channel. For applications of five or more channels, use the 8-channel DBK43A™ strain gage module.



The DBK16 allows connection of most strain gage types to a data acquisition system

Excitation Regulator. The DBK16 accepts user-supplied excitation input voltage from 12 to 16V on each channel. Its on-board excitation regulator can be adjusted from 1.5 to 10.5 VDC. The regulator's outputs have remote sensing terminals and feature 50 mA current limiting to prevent damage from short-circuits or overloads. The regulator's wide voltage range permits you to incorporate virtually any resistive or semi-conductive gage type.

Excitation Sources. The 12 to 16 VDC external excitation source required by the DBK16 can be supplied by the DBK30A rechargeable battery/excitation module or by a user-supplied source.

Input Amplifier. The DBK16's input amplifier provides an input gain range of x100 to x1250. Because input signals can vary widely in range, the DBK16's extensive range provides a better alternative to fixed-gain or slot-range amplifiers.

Offset & Scaling Gain. The DBK16's 0 to 5 VDC offset adjustment range and output gain scaling permit nulling of large quiescent loads and expansion of dynamic

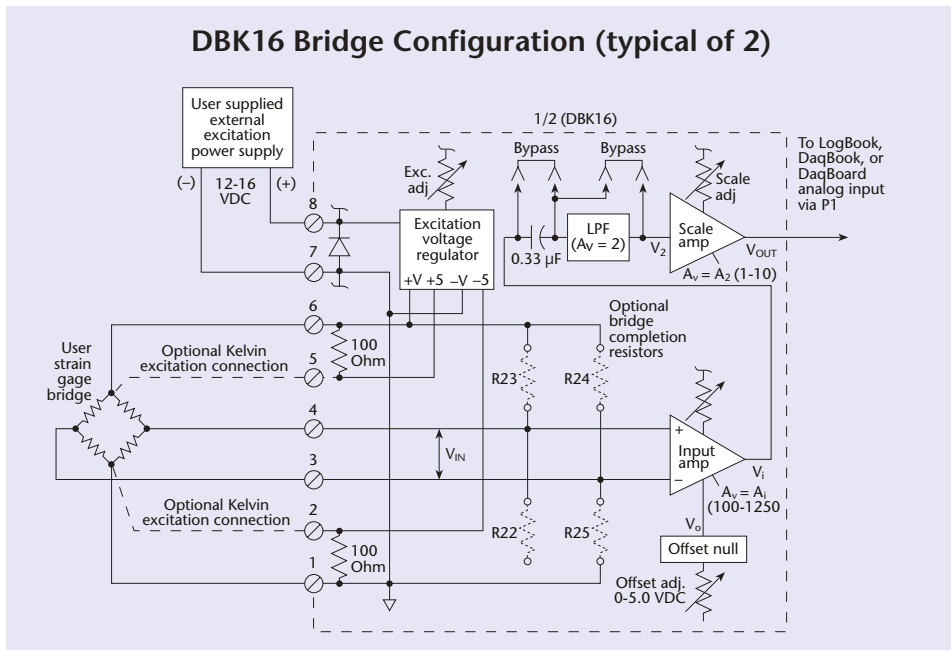

range for maximum resolution. This is an important feature because strain gages typically exhibit pre-load or quiescent output, leading to a non-zero output prior to the application of the load to be measured. The DBK16's offset adjustment is used to null these preload conditions. The remaining signal can then be expanded by the DBK16's output scaling amplifier to increase the resolution.

Coupling & Filtering. Each channel of the DBK16 offers switch-selectable AC or DC coupling between the input amplifier circuits and the filter stages. A selectable 3-pole low-pass filter with a user-customizable cutoff frequency is also provided. Elective capacitive coupling, which is selected via user-installable jumpers, allows you to separate dynamic signals from static deflection levels.



DBK16™

Specifications & Ordering Information

Software

The DBK16 includes GageCal™, a program that enables you to easily configure, calibrate, and set up your pressure or load cell application. The program features an intuitive graphical user interface (GUI) that guides you through the configuration of the DBK16 and its adjustment to the applied strain gage bridge.



You can easily configure the DBK16 via its Windows® software



The DBK16's software supports three calibration methods: nameplate, 2-point, and shunt

Bridge Completion Resistors. Physical locations are provided for up to four user-supplied bridge-completion resistors per channel, allowing you to accommodate virtually any type of external configuration without having to attach bridge completion resistors at the strain gage.

Specifications

Connector: DB37 male, mates with P1*; screw terminals provided for strain gage and external excitation connections

Number of Channels: 2

Excitation Voltage Adjustment Range:

1.50 to 10.50 VDC @ 50 mA

Gain Range: x100 to x1250

Accommodated Bridge Types:

Full Bridge, Kelvin Excitation (6-wire)

Full Bridge (4-wire)

Half Bridge (3-wire)

Quarter Bridge (2-wire)**

Bridge Resistors:

On-board locations are provided for four bridge-completion resistors per channel

Input Type: Differential

Input Impedance: 100M Ohm parallel with 100 pF

CMRR: 115 dB (DC to 60 Hz)

Excitation Voltage Source:

User-supplied 13 to 16 VDC @ 50 mA/channel

Excitation Current Output: 50 mA max

Excitation Sensing: Local or remote

Excitation Regulation

Line Regulation: 0.025%

Load Regulation: 0.05%

Reference Voltages: 2.5 VDC

Reference Accuracy: 0.05%

Reference Drift: 3 ppm/°C

Gain Calibration Reference: 5.00 mVDC

Reference Accuracy: 0.2%

Reference Drift: 20 ppm/°C; separate instrumentation amplifier for each channel, with gain adjustable from x100 to 1250 via externally accessible 15-turn trimpot

Gain Accuracy: 0.5%

Gain Drift: 50 ppm/°C

Input Offset: 100 µV max

Offset Drift: 4 µV/°C

Output Offset: 20 mV

Offset Drift: 200 µV/°C

Offset Adjustment: 0 to 100% of range, 0 to 5.00 VDC (15-turn trimpot)

Full-Scale Sensitivity Range

At 5.00 VDC Excitation: 0.8 to 10 mV/V

At 10.00 VDC Excitation: 0.4 to 5 mV/V

Scaling Amplifier Gain Range:

x1 to 10 (15-turn trimpot)

Low Pass Filter: 3 pole, user by-passable

-9 dB @ user changeable corner frequency (gain = x2); factory default: 3.5 Hz

Power Consumption: 1040 mW

Ordering Information

Description	Part No.
2-channel strain gage card	DBK16

Accessories

120 Ohm bridge completion resistor	BCR/120/1
350 Ohm bridge completion resistor	BCR/350/1
1000 Ohm bridge completion resistor	BCR/1000/1

Cables

For use with DBK10, use CA-37-x ribbon cable, or contact factory of additional cabling options

For use with DBK60 or LogBook360, no cable is required (except from DBK60 or LogBook/360 to the A/D mainframe)

For use with no enclosure, use CA-37-x where x is the number of DBK devices attached

For use with DaqLab series (internal slots), use CA-255-2T with one board, or CA-37-2 for use with two DBK cards (or contact factory for additional cabling options)

For complete information on accessories and cables, visit www.iotech.com/acc

Related Products

LogBook	p. 75
DaqBook	p. 89
DaqLab	p. 103
DaqScan	p. 108
DBK10	p. 126
DBK41	p. 146
DBK43A	p. 150
DBK60	p. 160
DaqBoard/2000 Series	p. 192

* Attachment to the DaqBoard/2000 series requires a DBK200, DBK201, DBK202, DBK203, DBK205, or DBK209 adapter

** Contact factory for 3-wire connection